

## Adjustable Pulse Valve

The R-341 delay valve may be used to provide an adjustable pulse (N.C.) or adjustable off (N.O.) signal. When an input occurs at port 7 it immediately pilots the valve and gives a signal at ports 2 & 8, which extends C-1. The same input is also being delayed through the flow control (between 7 & 4) until enough pressure builds up to actuate the auxiliary pilot which, together with the spring, overcomes the opposite pilot and shifts the valve shutting off the output. C-1 then retracts. The input must be removed before the valve will reset and cycle again. Since the input is separate from the supply and output valving, separate pressures or fluids can be used in the valve. Pulse times can range from 25 ms to 5 seconds. The second drawing shows the R-341 piped Normally-Open. The same sequence applies as above, only the valve is going off for a period instead of on.

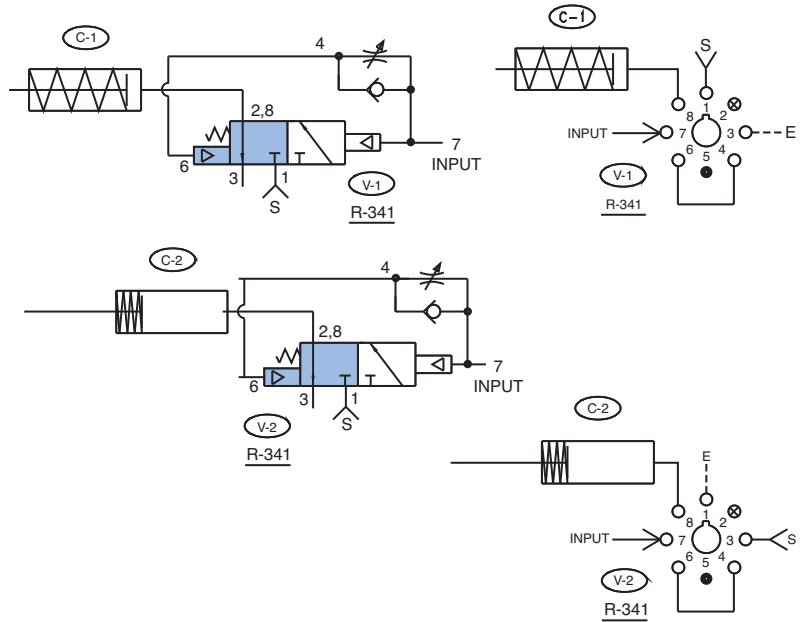

## Set-Reset Circuits

Shown are three examples of set-reset circuits, also called "latch" circuits. There are many ways to set or reset a valve or group valves. These examples make use of the unique auxiliary pilots available on many of the modular valves.

A set occurs when a valve is actuated and part of the output is used to hold the valve in the actuated position, even though the original pilot signal may be gone.

Generally a circuit is reset by interrupting the "set" pilot line or air supply to the valve when an opposite pilot is present to shift the valve. The modular auxiliary pilot, in combination with the valve spring, will overcome any or all opposite pilot(s) to reset the circuit.

